

Model Name	AXN10B600G
Maximum Power (+3%)	<b>600W</b>
Voc (V)	51.84
Isc (A)	13.67
Vmp (V)	46.08
Imp (A)	13.03
Module Efficiency (%)	23.0%
Series Fuse Rating	30A
Junction Box Protection	IP68
Maximum System Voltage	VDC1500
Operating Temperature	-40°C to 85°C
Module type	Framed Bi-Facial Double Glass
Connector type	Staubli EVO-2A
Cable length	12AWG 1200mm <sup>ii</sup>
Maximum snow/wind load	5400Pa(snow)/5400Pa(wind)
Certification/Fire Type	UL61730 <sup>ii</sup> ; UL1703 Fire Type 3

Total power output for different bi-facial gain coefficients				
	5%	10%	20%	30%
Maximum Power (+3%)	<b>630W</b>	<b>660W</b>	<b>721W</b>	<b>781W</b>
Voc (V)	51.84	51.84	51.84	51.84
Isc (A)	14.35	15.04	16.40	17.77
Vmp (V)	46.08	46.08	46.08	46.08
Imp (A)	13.68	14.33	15.64	16.94
Module Efficiency (%)	32.3%	33.8%	36.9%	40.0%

Bi-Facial modules produce power on both front and back. The actual power output from the back side is determined by installation conditions. Nominal bi-facial module gain coefficient can run from 5% to 30% or more, depending on the installation height and the amount of indirect irradiance. It is recommended to design the electrical circuits with safety factor that accounts for the additional power in order to protect electrical hardware.

i) Amphenol connectors available upon request, ii) Cable length may be customized, iii) Additional certifications available upon request

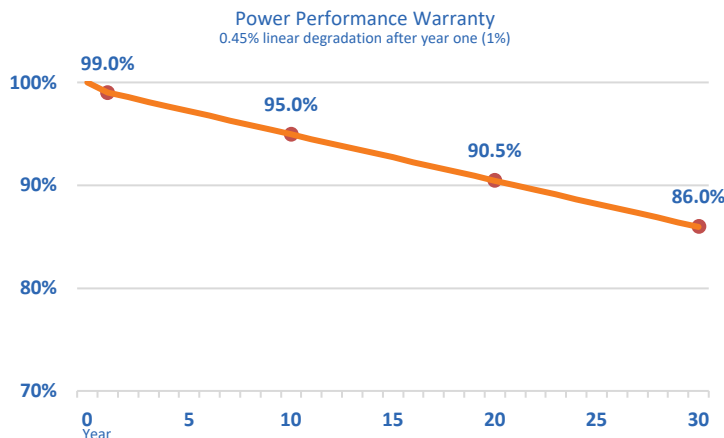
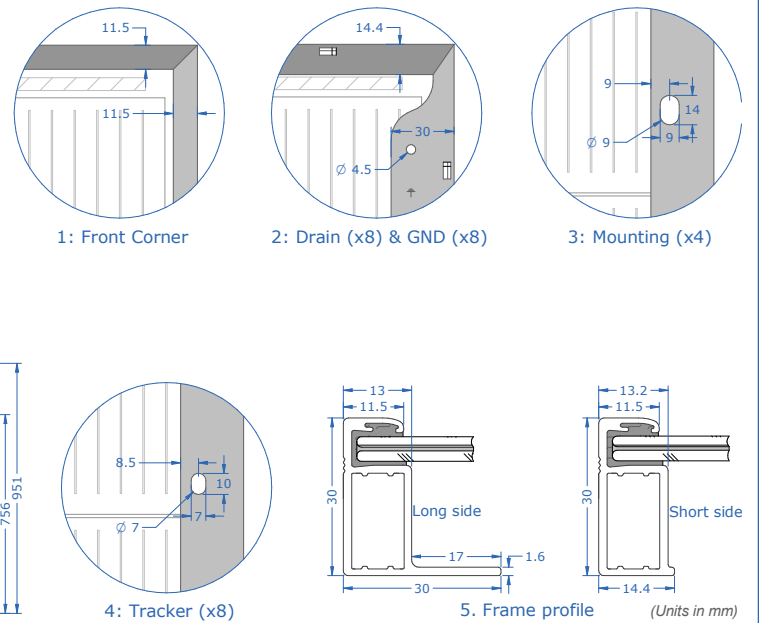
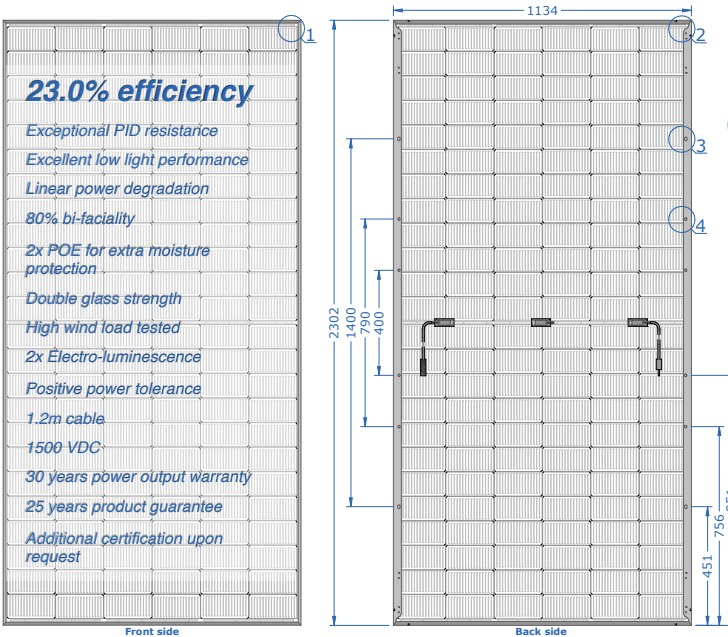

Mechanical Characteristics	
Frame	Anodized Aluminum (Silver and Black)
Solar Panel	69.99 lbs/31.75 kg 90.63" x 44.65" x 1.18" 2302mm x 1134mm x 30mm
Shipping Pallet	36 pcs per pallet 2613 lbs/1185 kgs 94.65" x 48.66" x 47.52" 2404mm x 1236mm x 1207mm
Container	16 pallets (576 pcs) per 53'

Temperature Coefficients		Standard Test Conditions (STC)	
NOCT	45 °C	Irradiance	1000W/m <sup>2</sup>
Isc/Voc (per °C)	+0.05%/-0.25%	Module Temperature	25 °C
Pmax (per °C)	-0.29%	AM	1.50

Specifications subject to change without notice